

## FUEL CELLS: STATE OF THE ART\*

I. G. Gurevich

*A review of the works of the last decade (1946–1956) is given. Reviews of extensive literature on this topic were published in 1922 [4], 1933 [5], 1945 [6]. In Russian, a large body of review material is contained in O. K. Davtyan's monograph [7].*

The last few years have seen an increasing frequency of appearance in the scientific-technical literature of articles and reports concerning the problem of the fuel cell. Publication of such reports in publicity departments and commercial magazines [1, 2] points to the fact that fuel cells have begun to acquire practical importance.

By the term "fuel cell" is meant an electrochemical method of electric energy generation in which chemical energy of a fuel is converted directly to electric energy. In other words, the original method of electric energy production with the use of a galvanic cell is meant. The basis of the conventional galvanic cell is the following system:



The electric energy generated in such a system is due to the chemical oxidation and reduction reactions proceeding on the interfaces. A fuel cell is a kind of a galvanic cell differing from the conventional cell by the fact that in the electric energy generating system metals are replaced by a fuel, on the one hand, and oxygen on the other.

So, the problem of the fuel cell is not new: it has a more than a century-and-a half history. The first attempts to create a fuel cell were made as long ago as 1801 [3]. However, with the advent in the latter half of the 19th century of the d.c. generator which permitted mechanical- (and consequently thermal)-to-electric energy conversion, i.e., electric energy generation by using, in the final analysis, the same chemical energy of the fuel, the interest in developing and improving fuel cells dropped. The new method had the indisputable advantage that it made it possible to begin large-scale and quick adoption of electric energy for industrial and domestic applications. Scientists and engineers made every effort to develop this method, and only enthusiasts continued to deal with fuel cells. Due to their work in of the first half of the century many various designs of the fuel cell appeared. While the absence of noticeable progress in the development of fuel cells led to the fact that they, according to Watson [8], turned into a kind of a "scarecrow" for all electrochemists, this laborious work of many years, which required desperate efforts, served as the basis for a satisfactory solution of the fuel cell problem that has recently taken shape.

The last few years have seen renewed interest in fuel cells due to the progress made in their development, on the one hand, and in connection with the growing requirements of mankind for electric energy and the necessity of saving the limited storage of fuel, on the other. The latter set a task for science to both find new energy sources and elaborate in accordance with them new methods of electric energy generation and improve the old ones in order to upgrade their economical efficiency. As for the improvement of the steam-power cycle currently used at electric power stations, despite certain achievements (steam of high parameters, etc.) it is in principle impossible to make considerable advances with it because of the known thermodynamical restrictions. As a result of the achievements in the creation of nuclear power stations, it may look as if fuel cells will go out of use before reaching the stage of wide practical application. However, in the opinion of many researchers, the existing situation shows that many more years will be needed before nuclear power stations will be able to carry the whole weight of the annually increasing total requirement for electric energy.

In the last few years investigations of fuel cells have been carried out especially actively in Germany, England, the USA, and the Netherlands. In the USSR such work has been performed by Spiridonov in the laboratory of Academician A. N. Frumkin and by O. K. Davtyan at the Energy Institute, USSR Academy of Sciences.

---

\*This article was first published in Inzh.-Fiz. Zh., No. 2, 1958.

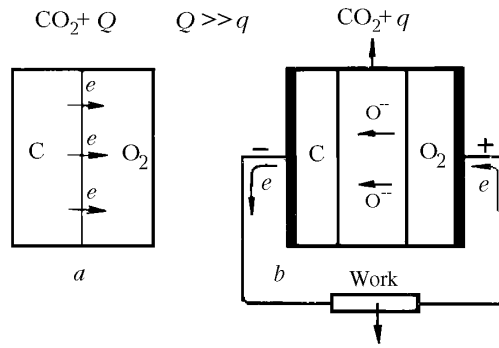

Fig. 1. Basic diagrams of chemical (a) and electrochemical (b) combustion.

**Main Point of the Problem.** The possibility of direct conversion of the chemical energy of a fuel to electric energy follows from the electrical nature of the chemical energy of elements and compounds. Thermal energy released by the conventional burning of a fuel is energy released as a result of the restructuring of the electron shells of fuel atoms (in particular, carbon, hydrogen) and oxygen. Restructuring (in the case of using coal as a fuel) shows up as a loss of electrons by carbon atoms (i.e., carbon oxidation) and their addition to oxygen atoms (in other words, reduction of oxygen);  $C^{4+}$  and  $O^{2-}$  ions formed combine to form  $CO_2$  molecules. The motion of electrons associated with this restructuring can be compared to the short-circuit current between atoms followed by the conversion of the whole of the chemical (electrical) energy of reactants to thermal energy. As is known, perfection of the process of heat conversion to mechanical work is determined by the thermodynamic efficiency  $\eta$ . In the best case (steam of high parameters), the value can reach 0.6–0.7. But at present the total efficiency of a heat engine does not exceed 30–35%. Thus, the low efficiency of the present-day power stations, not only thermal but also nuclear ones, is due to the presence in the electric energy generation process of a steam-power cycle.

If we prevent the appearance of short circuit current by separating in space the processes of atomic restructuring (oxidation and reduction), i.e., go to the scheme of a galvanic cell, we can obtain a much greater portion of energy released in these processes in the form of electric energy. If the carbon and oxygen are separated by an electrolyte, then the reaction between them can occur only as a result of the formation of corresponding ions and their interaction after they pass through the electrolyte. To maintain this reaction, the electrons should be removed from the carbon electrode and transferred to the oxygen on the other side of the electrolyte, and this is attained by closing the electric circuit outside the cell.

Thus, the difference between the chemical and electrochemical reactions (as applied to fuel combustion) is that the latter incorporates the transfer of electrons along the external path and is accompanied by a release (or even absorption) of a much smaller quantity of heat (Fig. 1). This is why the electrochemical reaction between the hydrogen and the fuel is called "cold combustion."

The work that electrons can deliver when moving over the external circuit depends on the electromotive force (emf) arising in the cell. In the regime of idle running (without load), the fuel element can be considered as a thermodynamically reversible device in which the emf depends only on the temperature, the pressure, and the reaction. For such a regime, the relation between the chemical energy measured by the thermal effect of the process and the electric energy measured by the maximum work is given by the known Gibbs–Helmholz equation

$$EnF = -\Delta H + TnF \left( \frac{\partial E}{\partial T} \right)_p, \quad (1)$$

where  $EnF$  is the electric work of the galvanic cell.

From Eq. (1) it follows that also in the case of "electrochemical combustion" of the fuel not the whole of the chemical energy can change to electric energy. From the expression for the emf

$$E = -\frac{\Delta H}{nF} + T \left( \frac{\partial E}{\partial T} \right)_p \quad (2)$$

TABLE 1. Temperature Dependences of the Basic Indices of Chemical Reactions

Reaction	Parameter	Temperature, °C						
		25	227	727	1227	1727	2227	2727
$2\text{H}_2 + \text{O}_2 \rightarrow 2\text{H}_2\text{O}$	$E, \text{V}$	1.227	1.13	0.991	0.841	0.686	0.536	0.386
	$\eta, \%$	82.8	89.6	77.2	64.6	52.8	42.2	33.3
$2\text{CO} + \text{O}_2 \rightarrow 2\text{CO}_2$	$E, \text{V}$	1.336	1.24	0.999	0.764	0.533	0.306	0.077
	$\eta, \%$	90.5	83.8	67.7	52.1	36.9	21.2	5.31
$\text{C} + \text{O}_2 \rightarrow \text{CO}_2$	$E, \text{V}$	1.02	1.02	1.01	1.01	1.0	0.99	0.989
	$\eta, \%$	99.8	99.5	99.0	98.5	97.8	96.1	95.0
$2\text{C} + \text{O}_2 \rightarrow 2\text{CO}^*$	$E, \text{V}$	0.702	0.795	1.025	1.25	1.54	1.673	1.899
	$\eta, \%$	123.8	140.9	180.4	214.6	244.7	271.7	305.2

it is seen that if the emf increases with increasing temperature, i.e., if the temperature coefficient of the emf is positive  $\left[\left(\frac{\partial E}{\partial T}\right)_p > 0\right]$ , then the whole of the chemical energy of the reaction plus the heat taken from the environment (pro-

vided that the cell is not insulated in terms of heat) is converted to electric energy. If  $\left(\frac{\partial E}{\partial T}\right)_p < 0$ , then not the whole of the chemical energy is converted, and part of it is released in the form of heat and heats the cell.

Table 1 presents reactions which can serve as a basis for a fuel cell and their corresponding emf and efficiencies depending on the temperature.\*\*

As for the dependence of the emf on partial pressures of the gases participating and forming in the course of the reaction, calculations show that this dependence is insignificant. From this a tempting possibility of using in the fuel cell poor combustible gases and air (instead of oxygen) without a noticeable decrease in the emf follows.

Thus, theoretically it appears that within certain temperature limits electrochemical generation of electric energy can occur with an efficiency much higher than that of thermal power stations.

The creation of a real fuel cell entails great difficulties, because all kinds of solid, fluid, and gaseous fuel (except for hydrogen) at normal temperature are not electrochemically active. Apart from these specific difficulties there are also difficulties that are generally characteristic of galvanic cells and are associated with a marked decrease in voltage with increasing load current.

The loss of the fuel cell energy under operating conditions (with a load) are due to two reasons. The first one is associated with the nonelectrochemical use of some part of the fuel and oxidizer as a result of their interaction with the materials used in the cell and with each other in molecular form. The second reason is associated with the irreversible character of the work of the loaded cell, i.e., with the finite value of the electrochemical reaction rate. Three sources of energy losses of the second kind are distinguished:

1. Losses due to the motion of fuel and oxidizer ions in the electrolyte; these are determined by the *internal resistance of the cell*.
2. Losses due to the change in the concentration of ions near the electrodes, i.e., the so-called *concentration polarization*.
3. Losses due to the slowness of the processes proceeding on the surface of electrodes and consisting of activation of the fuel and oxidizer, in other words, to the so-called *activation (chemical) polarization*.

Both kinds of polarization losses depend complexly on the density of the current taken up from the cell. In summarized form, all the three sources of energy losses appear as a voltage drop in the fuel cell.

In the light of such analysis of the energy losses, it is customary to characterize the real fuel cell by two indices:

- 1) efficiency with which delivered heat is used in the electrochemical reaction;
- 2) efficiency of the electrochemical reaction itself in the electric energy generation.

\* At limited access to oxygen, as well as at high temperatures  $>700^\circ\text{C}$ .

\*\* emf values are given for a pressure of 1 atm [7].

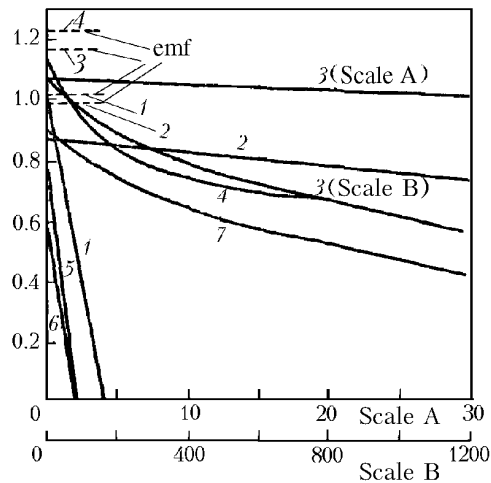

Fig. 2. Volt-ampere characteristics of different fuel cells (the horizontal axis shows the current density in  $\text{mA}/\text{cm}^2$ , the vertical axis presents voltage in volts): 1) Bischoff-Justi cell ( $\text{C} + \text{O}_2 \rightarrow \text{CO}_2$ ,  $700^\circ\text{C}$ , 1 atm); 2) Davtyan cell ( $50\% \text{CO} + 50\% \text{H}_2 + \text{O}_2 \rightarrow \text{CO}_2 + \text{H}_2\text{O}$ ,  $700^\circ\text{C}$ , 1 atm); 3) Bacon cell ( $2\text{H}_2 + \text{O}_2 \rightarrow 2\text{H}_2\text{O}$ ,  $240^\circ\text{C}$ , 55 atm); 4) Davtyan cell ( $2\text{H}_2 + \text{O}_2 \rightarrow 2\text{H}_2\text{O}$ ,  $25^\circ\text{C}$ , 1 atm); 5, 6) cells of [18] ( $2\text{H}_2 + \text{O}_2 \rightarrow 2\text{H}_2\text{O}$ ,  $25^\circ\text{C}$ , 1 atm); 7) Posner cell [22].

Since the current produced by the cell is proportional to the quantity of fuel expended electrochemically per unit time, the first of the indices can be referred to as the current utilization factor ( $\eta_c$ ) and defined as the ratio of the quantity of electricity actually transferred in the cell per unit time to the theoretically possible one. At a given current value the power of the cell depends on the voltage on its terminals ( $U$ ). Thus, the second voltage corresponds to the voltage utilization factors ( $\eta_v$ ). The total efficiency of the fuel cell is determined by the product of the two indices

$$\eta_{f.c} = \eta_c \eta_v = \frac{n'F}{nF} \frac{U}{E}.$$

The voltage drop in the cell with increasing load current is one of the major indices of operation and is given by its volt-ampere characteristic (Fig. 2).

The above energy losses can minimize the efficiency gain which the electrochemical method of electric energy generation provides. Their decrease is a result of the investigations of many years and is achieved by increasing the working temperature and partial pressures of gases and by a proper choice of the system geometry, the electrolyte composition, the materials of electrodes, and catalysts.

**Kinds of Fuel Cells.** It is natural to subdivide fuel cells into two main kinds:

- 1) direct cells, in which carbon is used as a fuel electrode;
- 2) indirect cells, in which combustible products of some reactions (e.g., water gas, producer gas, hydrogen) are used as a fuel electrode. In principle, they can also be named gas cells.

Dividing cells into reversible and irreversible ones (reversibility in the physical sense is meant) is also essential. For instance, a carbon-oxygen cell is irreversible, since the reaction proceeding in it ( $\text{C} + \text{O}_2 \rightarrow \text{CO}_2$ ) cannot be "reversed" by passing current in the opposite direction; a hydrogen-oxygen cell is reversible in this sense.

Moreover, some researchers subdivide fuel cells into high-temperature and low-temperature and high- and low-pressure cells, which is rather schematic.

*Direct cells.* On the face of it, the direct cell is the most attractive. However, because at room temperature carbon is practically not ionized, implementing such a cell requires high working temperatures ( $\approx 1000^\circ\text{C}$ ). This is due to the passing from aqueous electrolytes, which would require extremely high pressures, to molten and solid ones.

TABLE 2. Characteristics of the Fuel Cells

Cell and reaction	Internal resistance, $\Omega/\text{cm}^2$	Current density, $\text{mA}/\text{cm}^2$	Output power, $\text{mW}/\text{cm}^2$	$\eta_v$ , %	$\eta_c$ , %	Relative size of cell
Bischoff–Justi cell ( $\text{C} + \text{O}_2 \rightarrow \text{CO}_2$ at $700^\circ\text{C}$ , 1 atm)	250	1	0.75	75	—	440
		2	1.0	50	—	330
Davtyan cell (50% CO + 50% $\text{H}_2 + \text{O}_2 \rightarrow \text{CO}_2 + \text{H}_2\text{O}$ at $700^\circ\text{C}$ , 1 atm)	3	10	8.2	84	—	40
		20	15.7	80	—	21
		30	22.8	77	—	15
Bacon cell ( $2\text{H}_2 + \text{O}_2 \rightarrow 2\text{H}_2\text{O}$ at $240^\circ\text{C}$ , 55 atm)	0.5	162	145.8	77	—	2
		413	330.4	68	100	1
		1076	645.6	51	—	0.5
Davtyan cell ( $2\text{H}_2 + \text{O}_2 \rightarrow 2\text{H}_2\text{O}$ ) at $25^\circ\text{C}$ , 1 atm)	—	5	4.1	67	—	80
		10	7.4	60	—	45
		20	13.6	55	—	24

Among the latter direct cells are the Bischoff–Justi cell [9, 10] with a molten electrolyte created in 1951 and the Bischoff–Justi–Spengler cell [11] with a solid electrolyte. In the first of them, powdery coal is used as a fuel, and the  $\text{Na}_2\text{CO}_3$  melt placed in a ceramic cylinder to decrease corrosion is used as an electrolyte. The working temperature of the cell ( $700^\circ\text{C}$ ) is limited by the formation at higher temperatures of carbon oxide instead of dioxide, which is accompanied by a decrease in  $\eta_c$  to a value not higher than 50%. The characteristic of the cell under load is given in Fig. 2 and Table 2. In the second cell, in which  $\text{Na}_2\text{CO}_3$  is also used as an electrolyte, it was possible for the first time to attain an emf value equal to 99% of the theoretical value and hold it for many months (though in the regime of idle running); under a load the cell failed in a few days.

Among the chief disadvantages of direct cells is the necessity of providing external heating, which would require more energy than the cell is able to give, and the necessity of using expensive chemically pure coal (otherwise it is impossible to remove the slag formed without disassembling the cell). All this in combination with a low current density and a short lifetime makes practical application of such cells unlikely.

*Indirect cells.* Of the indirect cells only the hydrogen-oxygen cell can operate at low temperatures, the other gas cells requiring high temperatures. The fact that combustible gases obtained directly from the gas generator have a high temperature eliminates the necessity for external heating of the element. Before 1935–1937 most gas cells operated at temperatures above  $500^\circ\text{C}$  with the use of molten salts as an electrolyte. Under operating conditions such cells lasted only a few hours. After Schottky [12] and Baur [13] used the so-called "solid electrolytes" it was possible to prolong the service life of the cell. Difficulties consisted of selecting such a composition of the electrolyte which would provide a high ionic conduction.

Much has been done in this field by O. K. Davtyan [7]. Figure 2 and Table 2 give the characteristics of Davtyan's fuel cell based on the reaction between the generator gas and the air. The system consisting of 43% of sodium carbonate, 27% of monazite, 20% of tungsten trioxide, and 10% of soda glass proved to be the best suitable. The best operating parameters pertain to a temperature of  $700^\circ\text{C}$ ; chemical polarization is absent. The disadvantages are cracking of the electrolyte upon heating and cooling of the cell and a still low current density. This Davtyan cell was also tested with hydrogen as a fuel.

The further improvement of such cells has been the subject of many works carried out abroad as part of the general program of scientific investigations in the field of high-temperature cells. The results of the investigations made in Holland [14] have shown that only aqueous solutions and melts of salts can be of any practical importance as electrolytes. In some German and Holland cells a "solid" electrolyte under operating conditions is essentially a melt of a mixture of salts in combination with a binding solid material, e.g., in the form of a porous ceramic plate. The latter is intended to prevent deformation of the electrolyte and adsorption of molten salts on the electrodes. The electrolyte of such a "design" makes it possible to offset both the disadvantage of the Davtyan cell consisting of electrolyte cracking and the chief disadvantage of the former cells with molten electrolytes: a short life because of the active interaction of a molten salt even with noble metals.

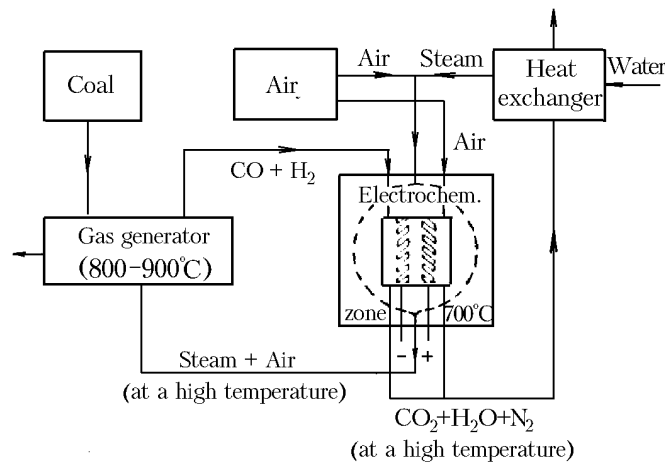

Fig. 3. Basic diagram of electrochemical application of the fuel (according to Gorin).

Of certain interest is the scheme of electrochemical burning of coal (Fig. 3) proposed in the USA in 1950–1952 by E. Gorin [15] and G. Genin [16]. Neither the process of coal gasification, nor the application of a gas battery, are novel inventions in themselves, but a combination of both these technical elements is something new, which enabled the Pittsburgh Coal Company to take out a patent for this scheme. It uses fuel cells similar to the Davtayan cell which operate at a temperature of  $700^{\circ}\text{C}$  (the gas generator operates at a temperature of  $900^{\circ}\text{C}$ ). The idea of the scheme is clear from Fig. 3: It is maximum recovery of the heat released during the operation of a fuel cell. It is used to maintain the endothermal reaction of coal gasification (by heating the steam-air mixture) and to obtain steam. Such a scheme permits upgrading the efficiency of the plant by 15% (57.4% and 42.8% without heat recovery). The lifetime of the fuel cell is doubtful because of the difficult working conditions; replacement of worn-out electrodes seems difficult. These and other disadvantages make problematic, so far, the employment of the above scheme for large-scale generation of electric energy.

Of all the gas fuel cells, the hydrogen-oxygen cell has the longest history. It began in 1839 when Grove [17] implemented for the first time a hydrogen-oxygen battery. The main problem, whose solution has been sought for more than a hundred years, is to increase the rate of the current-forming process so as to realize, with an economically reasonable efficiency, the ability of hydrogen to dissolve electrochemically at normal temperature, taking into account that a low temperature permits avoiding a whole number of disadvantages inherent in the high-temperature cells. It has been established that the question of accelerating the current-formation processes can be resolved by choosing proper carriers of gas electrodes able to catalytically activate the gases adsorbed by them and by increasing the gas-electrode contact surfaces. The latter is achieved by making electrodes in the form of brushes or spirals and using the so-called diffusion electrode representing a porous system through which gas molecules and ions diffuse.

A great deal of work on the investigation of hydrogen and oxygen electrode carriers has been done by O. K. Davtayan [7]. A result of this work is the hydrogen-oxygen cell (hydrogen cell of air depolarization), whose characteristic is given in Fig. 2 and Table 2. Each electrode is made of two punched and thin nickel-plated steel plates between which the corresponding carrier is located (for the hydrogen electrode it is a mixture of silver and activated carbon and for the oxygen one — a mixture of spongy nickel and activated carbon).

The difficulty that arises in all cells having gas electrodes and liquid electrolytes and consists of the necessity to prevent wetting of the electrode surfaces by the latter (otherwise the gas-adsorbing surface decreases) is resolved in the Davtayan cell by means of a semipermeable wax film making the electrodes nonwetttable.

A similar work has also been done recently in England [18]. The initial cell for it was a somewhat modified Davtayan cell. Instead of wax films, which turned out to be unstable in the presence of an alkali electrolyte, semipermeable diaphragms from a glass cloth covered with silicon varnish were tested. They stood without change for several months. But the internal resistance of the cell therewith increased almost five times compared to the Davtayan cell, and, accordingly, the cell voltage under the operating conditions dropped faster (Fig. 2). Moreover, the emf of these cells is only 0.73 V compared to 1.12 V (in Davtayan's cell) and 1.23 V (theoretical value). Such

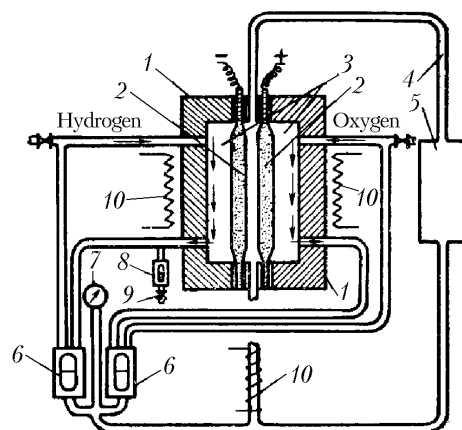

Fig. 4. Basic diagram of the Bacon cell: 1) case; 2) electrodes; 3) gas chambers; 4) electrolyte pipeline; 5) reservoir for electrolyte; 6) level gauges; 7) manometer; 8) condensate level gauge; 9) valve (for steam removal); 10) heaters.

a discrepancy is explained by the tendency of oxygen electrodes in an alkali medium to act as peroxide-hydrogen-oxygen (rather than hydrogen-oxygen) electrodes with a decrease in the electrode potential from 0.4 to 0.04 V (accordingly, the emf decreases to 0.87 V).

A further step in the development of the hydrogen-oxygen fuel cell is the Bacon cell [19] created at the chemical engineering department of the University of Cambridge. Works on a hydrogen-oxygen type cell were begun in England in 1938, interrupted at wartime, and resumed in 1946. The diagram of the laboratory prototype unit shown in Fig. 4 dates to 1952. Thus, about 10 years had passed before a hopeful result was obtained.

The fuel cell under consideration is made in the form of a steell cylinder consisting of two halves of height about 1.3 cm with an inner diameter of 12.7 cm; its inner surface is coated with nickel. The cell uses diffusion electrodes in the form of two-layer discs of thickness 0.4 cm: one layer has pores of size about 30  $\mu\text{m}$  and the second (thinner) layer has pores of size 16  $\mu\text{m}$ . Such electrodes are produced by sintering powdered nickel. Then the electrodes are activated by impregnation with nickel salts followed by their decomposition upon heating in a hydrogen atmosphere. They are mounted with the finely porous surfaces towards each other with a gap of the order of 0.16 cm. The interelectrode space is filled with the electrolyte (27% aqueous solution of KOH) continuously circulating under the action of the thermosyphon. Between the sheath and the electrodes gas chambers are located. To prevent wetting of the electrodes by the electrolyte, a small pressure drop is set on their cross-section, due to which the liquid can fill only the finely porous layer, thus preventing the gases from "bubbling" into the electrolyte. This eliminates the necessity for a semipermeable diaphragm. The inner surface of the coarsely porous layer provides a fairly large area for the adsorption of gases.

On the outer surface of the cell electrical heaters (in the form of coils) with thermostatic temperature control are mounted. All pipelines are made of nickel and are not heated (except for the pipeline with the electrolyte). The pressure difference on the electrode cross-sections is set by means of two water pressure gauges. A small reservoir for the electrolyte is included in the device to lessen the change in concentration with time when the cell operates under load. A special valve provides removal of water formed in the course of operation of the cell. At a load current equal to 30 A in 1 h in one cell about 10 ml of water is formed, so the quantity of condensate with which one has to deal with is small.

It has been established that the best operating temperature is 200°C. Using an aqueous electrolyte at higher temperatures requires that the cell operate under pressure. At the above temperature the pressure in the gas chambers settles at a value of about 30 atm. The characteristic of the cell is given in Fig. 2 and Table 2.

The high operating indices of the cell are explained, firstly, by the combination of the large area of the effective surface of electrodes with a relatively high temperature and, secondly, by the close relative position of the electrodes, and the electrolyte recirculation. All this has made it possible to lower the internal resistance of the cell to 0.5  $\Omega/\text{cm}^2$  and considerably decrease the chemical and concentration polarization. As a result, the generated current den-

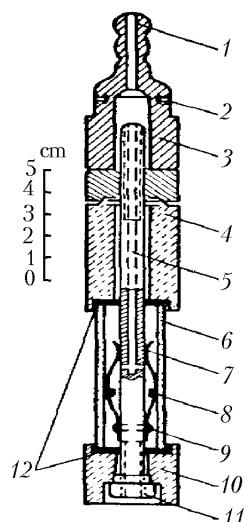

Fig. 5. Cross-section of the oxygen diffusion electrode: 1) gas inlet connection; 2) terminal jacks; 3) coupling head (metal); 4) upper insulator (acrylic plastic); 5) unclamping hollow roller (metal); 6) porous carbon cylinder; 7) contact springs; 8) contact rivets; 9) fixing rivet; 10) lower insulator (acrylic plastic); 11) nut; 12) packing ring.

sity in the Bacon fuel cell considerably exceeds the same characteristic of Davtyan's cell (e.g., at a voltage of 0.68 V it is 40 times higher). Some authors [20] are prone to see in this a special role of the temperature and pressure.

The chief disadvantage of Bacon's cell (and not only of his cell, but also all of the cells using catalysts) is the known sensitivity of most catalysts to contaminations by both gases (fuel and oxidizer); actually, it is possible to work only with absolutely pure gases, and their thorough purification is so expensive that, according to Prof. Justi, use of Bacon's cell as a primary cell is practically excluded. Moreover, the operating temperature of the cell is still too high, which leads to its complication and a short lifetime (a quaranteed service life of 1000 h is given).

The work of E. Justi [11] opens up new prospects. He has developed a hydrogen-oxygen cell operating already in the time interval between 25 and 100°C and not requiring, consequently, a high pressure. Under these conditions the cell provides a current density higher than Bacon's cell (a value of the short circuit current of 700 mA/cm<sup>2</sup> is given). The cell consists of two diffusion electrodes immersed in a vessel with a 27% aqueous solution of KOH. The structural arrangement of the oxygen electrode is presented in Fig. 5. A hollow cylinder from porous carbon into which oxygen is pumped at a pressure of about 1.5 atm serves as a diffusion diaphragm. There is no need therewith for any catalyzing additives; the catalytic activity of the carbon electrode is based on its special structure as to the number of pores and their size. The hydrogen electrode is made of nickel and operates similarly to the oxygen electrode but again due to the special kind of its porosity. The advantage of the cell is the fact that it permits obtaining a significant current density at an insignificant internal resistance. Moreover, unlike the Bacon cell, it is quite insensitive to contaminations of the gases, which has been proved by its employment for many months with gases of normal commercial purity [21].

*Fuel cell of the redox type.* Cells of the so-called redox type ("Redox Cells"), interest in which has been recently renewed, form a somewhat different group. At the present time in England the suitability of a large number of redox systems that can be used to implement a fuel cell is under investigation.

A redox fuel cell is essentially a concentrated galvanic cell whose emf depends on the concentration ratio between oxidic and monoxidic ions that are present in the solutions near two inert electrodes (anolyte and catholyte). For the concentration difference to be kept constant, both solutions should, respectively, reduce and oxidize. For the oxidizer oxygen and for the reducer the fuel (in a particular state) can be used.

Thus, the main idea on which the operation of a redox type fuel cell is based is to limit the reactions proceeding in the cell itself to ionic reactions and conduct at the same time reactions with the fuel and oxygen outside the cell. The anolyte (solution flowing around the anode) circulates between the cell and the reservoir in which oxygen



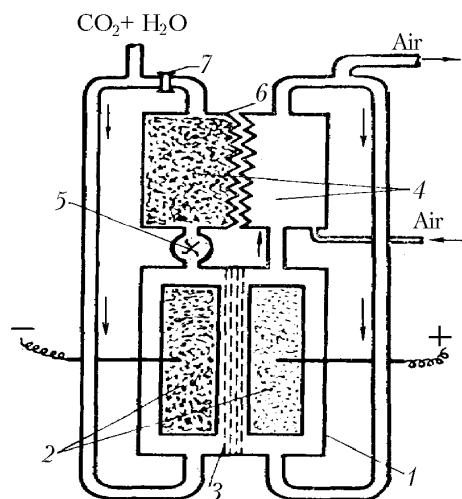

Fig. 6. Basic diagram of the redox fuel cell: 1) case; 2) inert electrodes (from porous carbon); 3) semipermeable diaphragm; 4) regenerators; 5) compressor; 6) heat exchanger; 7) reducing valve.

is used to oxidize monoxidic ions to oxidic ones, and the catholyte (solution flowing around the cathode) circulates between the cell and the vessel in which oxidic ions are reduced to monoxidic ones by means of the fuel. A necessary accessory to this cell is a semipermeable diaphragm that separates the catholyte and anolyte and at the same time does not interfere with the ion exchange.

The advantages of such a fuel cell are, firstly, the fact that the ionic reactions proceed at high rates and small energy losses even at normal temperatures and, secondly, the freedom of choosing conditions for conducting reactions with the fuel and oxygen, which permits using higher temperatures and pressures, low-grade coals (because of easy ash removal) and catalysts, etc.

The main problem concerning the cell under consideration is the choice of a redox system providing a high emf value and incorporating at the same time ions quickly reacting with the fuel and oxygen without side reactions leading to energy losses. A. M. Posner [22] published some results of experimental studies in this field (the fuel cell is schematically represented in Fig. 6 and its characteristic is given in Fig. 2 and Table 2). For inert electrodes, porous carbon was chosen. The anolyte is a system consisting of bromine (bromine-bromide) ions and the catholyte is a system consisting of bivalent and tetravalent tin compounds. Under idle running conditions such a system provided an emf equal to 0.91 V; at a current density equal to 55 mA/cm<sup>2</sup> the cell voltage drops to 0.27 V, pointing to significant polarization losses (the internal resistance of the cell is of the order of 0.1 Ω/cm<sup>2</sup>). Due to the fact that during the anolyte regeneration heat is released and during the regeneration of the catholyte it is absorbed (or vice versa depending on the chosen system) the structural arrangement of the cell should promote the internal heat exchange.

Because a whole number of problems have not been solved, it is too early to judge the efficiency of the redox cell.

**Some Conclusions and Prospects of Using Fuel Cells.** Analysis of the presented results of investigations in the field of fuel cells permits some conclusions.

The point of the problem that is still to be solved is to intensify the current-generating processes proceeding in the cell so that it is possible to realize those economical advantages which the electrochemical fuel burning gives. In the final analysis, it is the rate of these processes that determines the basic index of operation of the cell: current density in the load.

Solving the above problem by increasing the operating temperature and pressure is contrary to the requirement that the service life of the cell should be increased maximally. Combining high pressure and high temperature with aggressive electrolytes creates extremely difficult operating conditions for the materials entering into the cell and leads to their fast wear because of corrosion. Moreover, high temperatures call for the use of solid or molten electrolytes having a fairly high ohmic resistance to prevent the circulation of the electrolyte (which markedly decreases the concen-

tration polarization), plus a low diffusion rate in the solid the electrolytes. The use of various catalysts for the above purpose restricts the power supply of the cell to expensive chemically pure fuels.

Judging from the latest works of Bacon and Justi, of particular importance for the intensification of the processes in the cell is increasing the reaction surface (without increasing the visible area), which is attained by using diffusion electrodes for gas fuel cells. It should be noted that their importance is so great that in combination with the electrolyte circulation they make it possible to avoid the necessity of increasing the temperature and using catalysts, thus making it easier to resolve the question of longevity of fuel cells.

Apparently, apart from the chemical activation of the fuel and oxidizer, an important role in the operation of the fuel cell (in particular, of diffusion electrodes) is played by the phenomena of mass, charge, and heat transfer. Therefore, analysis of the processes proceeding in the cell from the viewpoint of transfer theory will make it possible to estimate the value of particular motive forces and their interrelationship and thus suggest ways for the rational design of fuel cells.

In connection with the practical importance of fuel cells in the last few years [23–28] questions of their most rational use are being discussed.

The low-voltage direct current obtained at the fuel cell output inhibits its wide application. Connecting cells into batteries permits obtaining the required voltages. It is especially easy to obtain gas batteries, because for them the problem of delivering fuel to each cell is simplified. This fact alone makes one give preference to gas cells. Direct-to-alternative current conversion will considerably complicate electrochemical power stations and increase their cost. This makes them stations of local application. Therefore, fuel cells will first find (and are already finding) application in electrochemistry and electrometallurgy, and for electric traction purposes, where low-voltage direct current is needed.

The most promising for applications is now the Justi hydrogen-oxygen cell. Because of the reversibility, the Bacon cell (along with the Justi cell) can be used to accumulate electric energy on a large scale, since unlike conventional accumulators water electrolysis products ( $H_2$  and  $O_2$ ) can be collected into cylinders. In this case, the size of the fuel cell will not determine its capacity. According to Bacon's calculations, the weight of the fuel cell, including the weight of the necessary gas vessels, will be 20 kg per 1 kW·h of accumulated energy. It is also planned to use cells on railroads to smooth loads at rush hours; they can help to resolve the question of wind energy accumulation and effective use of solar energy (applying it to the decomposition of water).

Before the Justi cell was developed, high-temperature gas cells (provided the question of longevity has been resolved successfully) acted as the only possible cell for large-scale electric energy generation, especially when combined with underground gasification of coals.

At present, final evaluation of the economic efficiency of using fuel cells for particular purposes cannot be made because of lack of service data.

## NOTATION

$E$ , emf, V;  $F$ , Faraday number;  $n$ , change in fuel valency upon its oxidation equal to the number of gram-equivalents;  $n'$ , number of actually used gram-equivalents of the fuel;  $T$ , temperature, K;  $U$ , voltage, V;  $\Delta H$ , thermal effect of the reaction;  $\eta$ , efficiency equal to the change in the heat content of the system, %. Subscripts:  $p$ , pressure;  $c$ , current;  $v$ , voltage; f.c., fuel cell.

## REFERENCES

1. *Electrical World*, No. 6, 30–31 (1955).
2. *Product Engineering*, **26**, No. 1, 201 (1955).
3. H. Davy, *Ann. Phys.*, **8**, 301 (1801).
4. E. K. Rideal and U. R. Evans, *Trans. Faraday Soc.*, **17**, 466 (1922).
5. E. Baur and I. Tobier, *Z. Electrochem.*, **39**, 169, (1933).
6. H. Howard, *Chemistry of Coal Utilization*, **2**, 1568–1585 (1945).
7. O. K. Davtyan, *The Problem of Direct Conversion of the Chemical Energy of a Fuel to Electrical Energy* [in Russian], Izd. AN SSSR, Moscow (1947).

8. R. G. H. Watson, *Direct Current*, **1**, No. 2, 30–34 (1952).
9. K. Bischoff, *Thesis, University of Bruswick, BWK*, **3**, No. 5, 154 (1951).
10. K. Bischoff and E. Justi, *Ann. Min. Belg.*, **52**, 381 (1953).
11. E. Justi, *Phys. Blatter*, No. 1, 11–15 (1956).
12. W. Schottky, *Wiss. veroff. Siemens-Konzern*, **14**, 1 (1935).
13. E. Baur, *Z. Electrochem.*, **43**, 727 (1937).
14. J. A. A. Ketelaar, *Ingenieur*, **66**, E. 85 (1954).
15. E. Gorin and H. Pittsburgh, *Consolidation Coal Co.*, U.S. Pat., 2570, 543 (1951); 2581, 650 (1952).
16. G. Genin, *Electricite*, **37**, No. 190, 1–7; No. 195, 125–132 (1953).
17. W. R. Grove, *Philos. Mag.*, **14**, 129 (1839).
18. A. M. Adams, *J. Inst. Fuel*, **27**, 366–373 (1954).
19. F. T. Bacon, *Beam J.*, **61**, No. 199, 6–12 (1954).
20. R. G. H. Watson, *Research*, **7**, No. 1, 34–40 (1954).
21. H. W. Hahnemann, *VDI Z.*, **98**, No. 1, 13 (1956).
22. A. M. Posner, *Fuel*, **34**, No. 3, 330 (1955).
23. A. M. Adams, *J. Inst. El. En.*, **2**, No. 13, 7–13 (1956).
24. K. Mackeel and A. M. Adams, *Fuel*, **28**, No. 1, 6–11 (1949).
25. P. V. Danckwerts, *Ind. Chem.*, **28**, No. 326, 99–102 (1952).
26. D. Y. Gastoue, *Tech. Mod.*, XLV, No. 3, 80–83 (1953).
27. *Ind. Eng. Chem.*, **46**, No. 10, 11–13A (1954).
28. *Mech. World Eng. Record*, **135**, No. 3426, 18–20 (1955).

Institute of Energetics, Academy of Sciences of BSSR, Minsk